

Overview

The LOKO (Lights On, Keys On) system is a 12V/24V system for activating autonomously your cars Headlights whilst your vehicle is running. This increases your cars visibility to other drivers and pedestrians and are commonly known as DRL (Daytime Running Lights).

DRL's and other daytime headlight activation systems have become a new standard feature in most European countries. This is because studies have shown that DRL and driving with your headlights active during the day can reduce up to 28% of fatal car accidents.

This is achieved by 3 x 30A microprocessor controlled relays (that can be wired for either ground or positive switching circuits) which are wired into your vehicles existing wiring and take control of your headlights. With features that include :-

- 10 Second delay at ignition to reduce battery starting load.
- Delay on exit. When the ignition is turned off the lights will stay illuminated for 10 seconds.
- Parking/Tail light functionality.
- Override function
- Custom delay time and Voltage cutout (Custom settings must be advised on order and are factory set. Conditions Apply)

Setup

Install LOKOS-1224 as per the wiring diagram on the reverse of this leaflet for the style of wiring that exists in your vehicle either positive or negative switching.

These wiring diagrams are for reference only, for exact wiring specifications for your model vehicle please consult a professional Auto Electrician or similar for wiring advice.

Optional Override - This can be installed to a switch in the vehicle that is negatively switched (i.e Handbrake, Door Switch) to turn off the vehicle lights when activated.

Internal Relay Layout

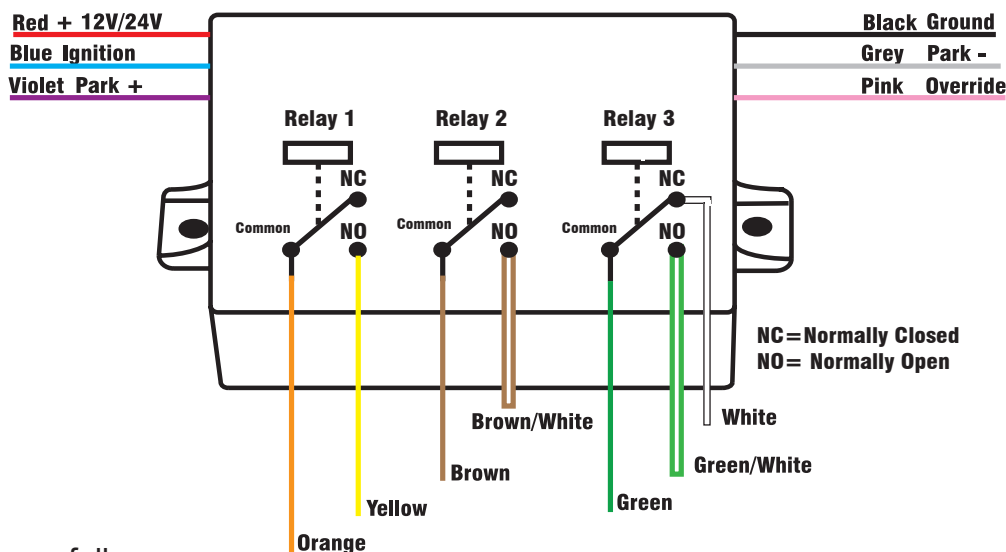

The unit operates as follows:

	Relay 1	Relay 2	Relay 3
When the ignition is connected the unit will connect all three Relays after 10 seconds.	■	■	■
If park light switch is turned on relays 1 and 3 will disconnect and relay 2 will remain connected.	■	■	■
If the Override is connected all three relays will turn off.	■	■	■
If the Parking light switch is turned on then the Override is connected the Relay 2 will stay connected.	■	■	■

Wiring Guide Standard LOW beam Installation

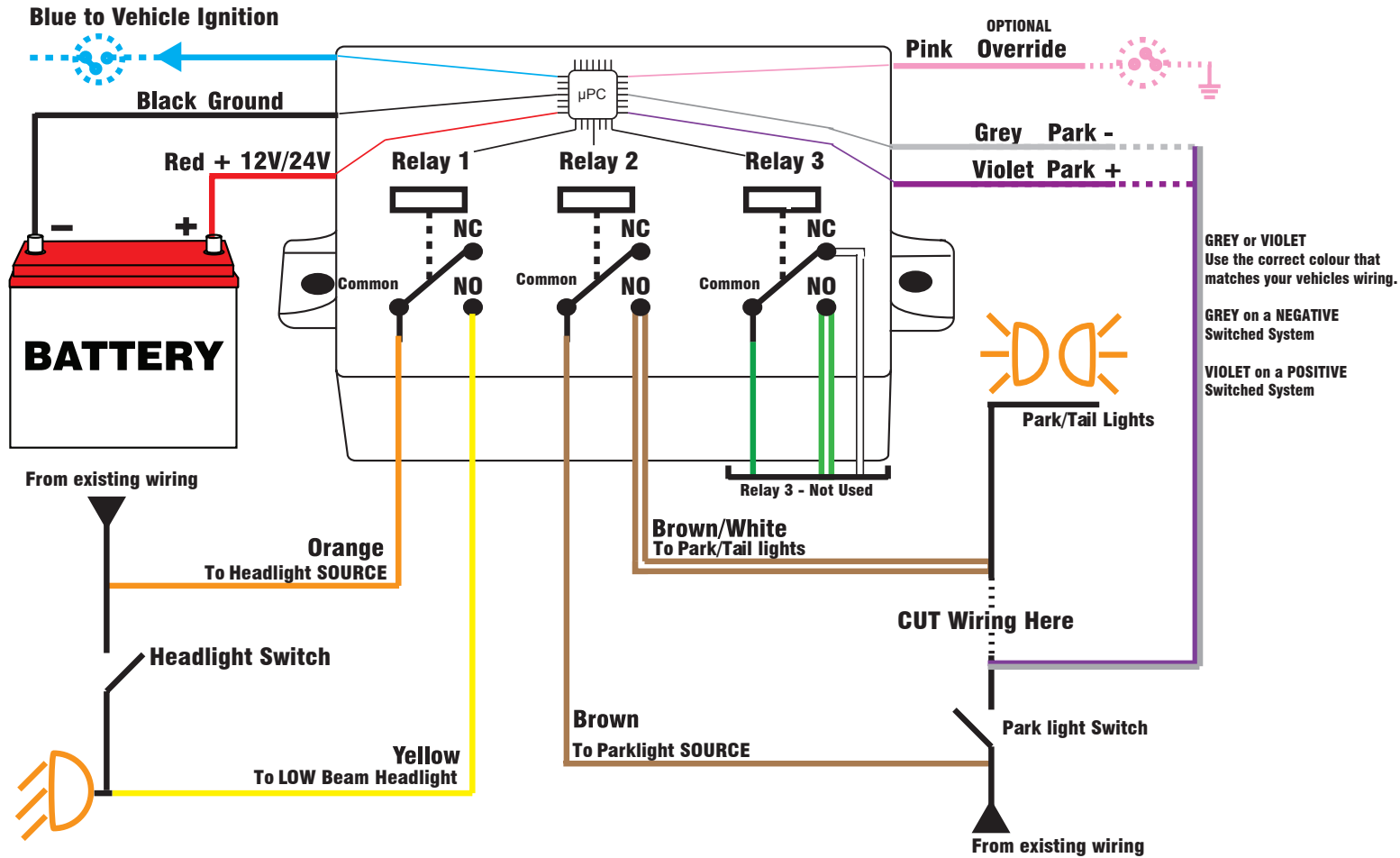

Notes: ALL unused connections should be taped up and secured out of the way.

SOURCE connections can be positive or negative this is established if the vehicle is fitted with negative switching or positive switching headlights and attach to the source of the Lights BEFORE the Lighting switch.

Warranty Conditions: The product is warranted to be free from defects in materials and workmanship under normal use and service for a period of 24 months from the date of sale. This warranty covers defective parts and workmanship provided that the product is shipped prepaid to the seller within 24 months of purchase of goods. This warranty is limited to the repair or replacement (at the manufacturers' discretion) of parts and shipping prepaid to the original despatch destination. We regret that no liability can be accepted for consequential or special damages of any kind howsoever arising in connection with products supplied by the seller. This warranty is in lieu of all other warranties expressed or implied. No representative is authorised to assume for the seller any other liability in connection with the seller's products.